

December 2019

ON THE PRODUCT OF TWO HYPOEXPONENTIAL RANDOM VARIABLES

Therrar Kadri

Faculty of Sciences, Lebanese International University, Lebanon, therrar.kadri@liu.edu.lb

Khaled Smaili

Faculty of Sciences, Lebanese University, Zahle, Lebanon, ksmeily@hotmail.com

Seifedine Kadry

Associate Professor, Faculty of Science, Beirut Arab University, Beirut, Lebanon, s.kadry@bau.edu.lb

Ali El-Joubbeh

Faculty of Sciences, Lebanese University, Zahle, Lebanon, ali_joubbeh@ul.edu.lb

Follow this and additional works at: <https://digitalcommons.bau.edu.lb/stjournal>



Part of the [Architecture Commons](#), [Business Commons](#), [Engineering Commons](#), and the [Physical Sciences and Mathematics Commons](#)

Recommended Citation

Kadri, Therrar; Smaili, Khaled; Kadry, Seifedine; and El-Joubbeh, Ali (2019) "ON THE PRODUCT OF TWO HYPOEXPONENTIAL RANDOM VARIABLES," *BAU Journal - Science and Technology*. Vol. 1 : Iss. 1 , Article 7.

Available at: <https://digitalcommons.bau.edu.lb/stjournal/vol1/iss1/7>

This Article is brought to you for free and open access by Digital Commons @ BAU. It has been accepted for inclusion in BAU Journal - Science and Technology by an authorized editor of Digital Commons @ BAU. For more information, please contact ibtihal@bau.edu.lb.

ON THE PRODUCT OF TWO HYPOEXPONENTIAL RANDOM VARIABLES

Abstract

In this paper, we consider the product of two independent Hypoexponential distributions which has many applications in sciences and engineering. We find analytically the probability density function, the cumulative distribution function, moment generating function, the reliability function and hazard function, which was proved to be a linear combination of the K distribution. Finally, we will apply our results application in stochastic PERT Network.

Keywords

Product Distribution, Hypoexponential Distribution; K Distribution; Probability Density Function; Reliability Function.

$$f_Z(t) = \int_0^{+\infty} \frac{1}{x} f_Y\left(\frac{t}{x}\right) f_X(x) dx = E\left[\frac{1}{x} f_Y\left(\frac{t}{x}\right)\right], \quad (2)$$

where $E[X]$ is the expectation of the random variable X . We note that the above expressions are symmetric in X and Y .

2.2 The Hypoexponential Distribution

The Hypoexponential distribution is the distribution of the sum of $m \geq 2$ independent Exponential random variables. The general case of the Hypoexponential distribution is when the m exponential stages do not have to be distinct. This general case can be written as $S_m = \sum_{i=1}^n \sum_{j=1}^{k_i} X_{ij}$, where X_{ij} is an Exponential RV of parameter α_i , $i = 1, 2, \dots, n$, and written as $S_m \sim \text{Hypoexp}(\vec{\alpha}, \vec{k})$ of parameters $\vec{\alpha} = (\alpha_1, \alpha_2, \dots, \alpha_n)$ and $\vec{k} = (k_1, k_2, \dots, k_n)$ with $m = \sum_{i=1}^n k_i$, see (Smaili, 2013b). Smaili et al. in (Smaili, 2013b) gave a modified expression for the PDF of the Hypoexponential random variable as

$$f_{S_m}(t) = \sum_{i=1}^n \sum_{j=1}^{k_i} A_{ij} f_{E_{ij}}(t) \quad (3)$$

where

$$f_{E_{ij}}(t) = \frac{(\alpha_i t)^{j-1} \alpha_i e^{-\alpha_i t}}{(j-1)!} \text{ if } t > 0 \quad (4)$$

and $f_{E_{ij}}(t) = 0$ if $t \leq 0$, is the PDF of the Erlang distribution E_{ij} with j the shape parameter and α_i the rate parameters, written as $E_{ij} \sim \text{Erl}(j, \alpha_i)$ for $1 \leq i \leq n$, $1 \leq j \leq k_i$. They showed that

$$\sum_{i=1}^n \sum_{j=1}^{k_i} A_{ij} = 1 \quad (5)$$

Moreover, they gave an expression of A_{ij} in a simple iterated form as for $1 \leq i \leq n$, $1 \leq j \leq k_i$ as

$$A_{i,k_i} = \prod_{j=1, j \neq i}^n \left(1 - \frac{\alpha_i}{\alpha_j}\right)^{-k_j} \quad (6)$$

and for $j = k_i - 1$, down to 1.

$$A_{ij} = \frac{1}{k_i - j} \sum_{l=1}^{k_i - j} \left[\left(\sum_{p=1, p \neq i}^n k_p \left(1 - \frac{\alpha_p}{\alpha_i}\right)^{-l} \right) A_{i,j+l} \right]. \quad (7)$$

However, the mean of S_m is given as

$$E[S_m] = \sum_{i=1}^n \frac{k_i}{\alpha_i} = \sum_{i=1}^n \sum_{j=1}^{k_i} A_{ij} \frac{j}{\alpha_i} \quad (8)$$

A particular case of this distribution is when the m stages are different. This case is written as $X \sim \text{Hypoexp}(\vec{\alpha})$, where $\vec{\alpha} = (\alpha_1, \alpha_2, \dots, \alpha_n)$, $\vec{k} = (1, 1, \dots, 1)$, see (Smaili, 2013a). From Eq. (3) we have the PDF is $f_{S_m}(t) = \sum_{i=1}^n \sum_{j=1}^{k_i} A_{ij} f_{E_{ij}}(t) = \sum_{i=1}^n A_{i1} f_{E_{i1}}(t)$. However, E_{i1} is the Exponential random variable with parameter α_i and $A_{i1} = \prod_{j=1, j \neq i}^n \left(\frac{\alpha_j}{\alpha_j - \alpha_i}\right) \triangleq A_i$, for $1 \leq i \leq n$, see (Smaili, 2013b). Then the PDF is

$$f_{S_m}(t) = \sum_{i=1}^n A_i \alpha_i e^{-\alpha_i t} \text{ for } t > 0 \quad (9)$$

Another particular case is when the m stages are identical and the distribution is the Erlang distribution. Taking in Eq (3) $\vec{\alpha} = (\alpha)$, $\vec{k} = (k)$ and $n = 1$, we write $X \sim \text{Hypoexp}(\alpha, k) = \text{Erl}(k, \alpha)$, see (Smali, 2013b). Moreover, in (Smali, 2013b), they showed that $A_{1j} = 0$ for $1 \leq j \leq k - 1$ and $A_{1,k} = 1$.

2.3 K distribution

Let X be a random variable that has a K -Distribution with three distribution having the shape parameters L and v and mean μ , denoted as $X \sim K(L, v, \mu)$, The PDF of X is given by

$$f(t) = \frac{2}{t} \left(\frac{Lvt}{\mu}\right)^{\frac{L+v}{2}} \frac{1}{\Gamma(L)\Gamma(v)} K_{v-L} \left(2\sqrt{\frac{Lvt}{\mu}}\right), \text{ for } t > 0 \tag{10}$$

where $K_p(\cdot)$ is the modified Bessel function of second kind of order p , see (Redding, 1999).

K -distribution arises as the consequence of a statistical or probabilistic model used in Synthetic Aperture Radar (SAR) imagery. The K -distribution is formed by compounding two separate probability distributions, one representing the radar cross-section, and the other representing speckle that is a characteristic of coherent imaging.

In the following Lemma, we present a modified form of the K -distribution as the product of two Erlang random variables. This form shall help us through out the paper to reach our results.

Lemma 1: Let $X \sim \text{Erl}(k, \alpha)$ and $Y \sim \text{Erl}(l, \beta)$ be two independent random variables where k and l are the shape parameters and the values α and β are the rate parameters. Let $Z = XY$. Then $Z \sim K(k, l, \frac{kl}{\alpha\beta})$ and its PDF has the following expression

$$f_Z(t) = \frac{2(\alpha\beta t)^{\frac{l+k}{2}}}{(l-1)!(k-1)!t} K_{l-k}(2\sqrt{\alpha\beta t}), \tag{11}$$

where $K_p(\cdot)$ is the modified Bessel function of second kind of order p .

Proof. Let $X \sim \text{Erl}(k, \alpha)$ and $Y \sim \text{Erl}(l, \beta)$. Then the PDF of $Z = XY$ is given from Eq (2) as

$$f_Z(t) = E\left[\frac{1}{x} f_Y\left(\frac{t}{x}\right)\right] \tag{12}$$

But $Y \sim \text{Erl}(l, \beta)$ then $f_Y\left(\frac{t}{x}\right)$ is obtained from Eq (4) as $f_Y\left(\frac{t}{x}\right) = \frac{\left(\frac{\beta t}{x}\right)^{l-1} \beta e^{-\frac{\beta t}{x}}}{(l-1)!}$. Hence, we have

$$\begin{aligned} f_Z(t) &= E\left[\frac{1}{x} \frac{\left(\frac{\beta t}{x}\right)^{l-1} \beta e^{-\frac{\beta t}{x}}}{(l-1)!}\right] = \int_0^\infty \frac{1}{x} \frac{\left(\frac{\beta t}{x}\right)^{l-1} \beta e^{-\frac{\beta t}{x}}}{(l-1)!} \frac{(ax)^{k-1} \alpha e^{-ax}}{(k-1)!} dx \\ &= \frac{\beta^l \alpha^k t^{l-1}}{(l-1)!(k-1)!} \int_0^\infty x^{-l+k-1} e^{-\frac{\beta t}{x} - ax} dx \end{aligned}$$

However, we have $\int_0^{+\infty} \frac{e^{-\frac{c}{x} - dx}}{x^a} dx = 2 \left(\frac{c}{d}\right)^{\frac{1-a}{2}} K_{a-1}(2\sqrt{cd})$. By setting $c = \beta t$, $d = \alpha$, $a = l - k + 1$, we obtain that

$$\begin{aligned} f_Z(t) &= \frac{\beta^l \alpha^k t^{l-1}}{(l-1)!(k-1)!} 2 \left(\frac{\beta t}{\alpha}\right)^{\frac{k-l}{2}} K_{l-k}(2\sqrt{\alpha\beta t}) \\ &= \frac{2\beta^{\frac{l+k}{2}} \alpha^{\frac{l+k}{2}} t^{\frac{k+l}{2}-1}}{(l-1)!(k-1)!} K_{l-k}(2\sqrt{\alpha\beta t}) \\ &= \frac{2(\alpha\beta t)^{\frac{l+k}{2}}}{(l-1)!(k-1)!t} K_{l-k}(2\sqrt{\alpha\beta t}) \end{aligned}$$

Now, the means of X and Y are given by $\mu_X = \frac{k}{\alpha}$ and $\mu_Y = \frac{l}{\beta}$, then $\mu_Z = \mu_X \mu_Y = \frac{kl}{\alpha\beta}$ we can rewrite the PDF of Z as

$$f_Z(t) = \frac{2\left(\frac{kl}{\mu_Z}t\right)^{\frac{l+k}{2}}}{(l-1)!(k-1)!t} K_{l-k}\left(2\sqrt{\frac{kl}{\mu_Z}}\right) \tag{13}$$

Then Z is the K -distribution with parameters k and l and mean $\mu_Z = \frac{kl}{\alpha\beta}$.

In the next Lemma we review some characteristics of this distribution. These expressions can be found in (Jakeman, 1978), (Redding, 1999), and (Ward, 1981).

Lemma 2: Let $X \sim K(k, l, \mu)$, and $\mu = \frac{kl}{\alpha\beta}$ in the case X is the product of $Erl(k, \alpha)$ and $Erl(l, \beta)$. Then

1. The Moment of X of order m is given by

$$E[X^m] = \mu^m \frac{\Gamma(k+m)\Gamma(l+m)}{k^m l^m \Gamma(k)\Gamma(l)} = \frac{\Gamma(k+m)\Gamma(l+m)}{\alpha^m \beta^m \Gamma(k)\Gamma(l)}$$

2. $E[X] = \mu = \frac{kl}{\alpha\beta}$.

3. $Var[X] = \mu^2 \left(\frac{k+l+1}{kl}\right) = \frac{kl(k+l+1)}{(\alpha\beta)^2}$.

4. The moment generating function of X is,

$$\Phi_X(t) = \left(\frac{kl}{\mu t}\right)^{\frac{k+l-1}{2}} e^{\frac{kl}{2t\mu}} W_{-\frac{k+l-1}{2}, \frac{k-l}{2}}\left(\frac{kl}{\mu t}\right) = \left(\frac{\alpha\beta}{t}\right)^{\frac{k+l-1}{2}} e^{\frac{\alpha\beta}{2t}} W_{-\frac{k+l-1}{2}, \frac{k-l}{2}}\left(\frac{\alpha\beta}{t}\right),$$

where $W_{a,b}(\cdot)$ where is the Whittaker function, see (Abramowitz, 1965).

3. PRODUCT OF TWO INDEPENDENT HYPOEXPONENTIAL DISTRIBUTIONS

In this section, we give the exact closed expression of the PDF of the product of two independent Hypoexponential distributions. The expression is given in the case of the general case of any two independent Hypoexponential distributions.

3.1 General Case

We suppose that X and Y follow the general case of the Hypoexponential distribution that are independent. We take $X \sim Hypoexp(\vec{\alpha}, \vec{k})$, $\vec{\alpha} = (\alpha_1, \alpha_2, \dots, \alpha_n)$, $\vec{k} = (k_1, k_2, \dots, k_n)$ and $Y \sim Hypoexp(\vec{\beta}, \vec{l})$, $\vec{\beta} = (\beta_1, \beta_2, \dots, \beta_r)$, $\vec{l} = (l_1, l_2, \dots, l_r)$. From Eq. (3) the PDFs of X and Y are

$$f_X(t) = \sum_{i=1}^n \sum_{j=1}^{k_i} A_{ij} f_{E_{\alpha_i, j}}(t) \text{ and } f_Y(t) = \sum_{p=1}^r \sum_{q=1}^{l_p} B_{pq} f_{E_{\beta_p, q}}(t) \tag{14}$$

respectively, where $E_{\omega, \delta} \sim Erl(\delta, \omega)$ and A_{ij} and B_{pq} are given in (6) and (7) for $1 \leq i \leq n$, $1 \leq j \leq k_i$, $1 \leq p \leq r$, and $1 \leq q \leq l_p$.

Theorem 1: Let $X \sim Hypoexp(\vec{\alpha}, \vec{k})$, $\vec{\alpha} = (\alpha_1, \alpha_2, \dots, \alpha_n)$, $\vec{k} = (k_1, k_2, \dots, k_n)$ and $Y \sim Hypoexp(\vec{\beta}, \vec{l})$, $\vec{\beta} = (\beta_1, \beta_2, \dots, \beta_r)$, $\vec{l} = (l_1, l_2, \dots, l_r)$. Then the PDF of $Z = XY$ is given by

$$f_Z(t) = \sum_{i=1}^n \sum_{j=1}^{k_i} \sum_{p=1}^r \sum_{q=1}^{l_p} A_{ij} B_{pq} f_K(t) \tag{15}$$

where $f_K(t)$ is the PDF of the K -distribution with parameters q, j and mean $\mu_K = \frac{qj}{\alpha_i \beta_p}$, and A_{ij} and B_{pq} are obtained from in (6) and (7).

Proof. The PDF of $Z = XY$ is given from Eq. (2) as

$$f_Z(t) = E\left[\frac{1}{x} f_Y\left(\frac{t}{x}\right)\right] = \int_0^\infty \frac{1}{x} f_Y\left(\frac{t}{x}\right) f_X(x) dx$$

Next, using the PDF of X and Y in (2) we get

$$\begin{aligned} f_Z(t) &= \int_0^\infty \frac{1}{x} \left(\sum_{p=1}^r \sum_{q=1}^{l_p} B_{pq} f_{E_{\beta_p, q}}\left(\frac{t}{x}\right)\right) \left(\sum_{i=1}^n \sum_{j=1}^{k_i} A_{ij} f_{E_{\alpha_i, j}}(x)\right) dx \\ &= \sum_{p=1}^r \sum_{q=1}^{l_p} \sum_{i=1}^n \sum_{j=1}^{k_i} B_{pq} A_{ij} \int_0^\infty \frac{1}{x} \left(f_{E_{\beta_p, q}}\left(\frac{t}{x}\right) f_{E_{\alpha_i, j}}(x)\right) dx \end{aligned}$$

but

$$\begin{aligned} f_{E_{\beta_p, q}}\left(\frac{t}{x}\right) f_{E_{\alpha_i, j}}(x) &= \frac{\left(\beta_p \frac{t}{x}\right)^{q-1} \beta_p e^{-\beta_p \left(\frac{t}{x}\right)} (\alpha_i x)^{j-1} \alpha_i e^{-\alpha_i x}}{(q-1)! (j-1)!} \\ &= \frac{\beta_p^q \alpha_i^j t^{q-1}}{(q-1)! (j-1)!} x^{-q+j} e^{-\frac{\beta_p t}{x} + \alpha_i x} \end{aligned}$$

then we have

$$f_Z(t) = \sum_{p=1}^r \sum_{q=1}^{l_p} \sum_{i=1}^n \sum_{j=1}^{k_i} B_{pq} A_{ij} \frac{\beta_p^q \alpha_i^j t^{q-1}}{(q-1)! (j-1)!} \int_0^\infty x^{-q+j-1} e^{-\frac{\beta_p t}{x} + \alpha_i x} dx. \quad (16)$$

Now, by using the following integral expression

$$\int_0^{+\infty} e^{-\frac{c}{x} + dx} dx = 2 \left(\frac{c}{d}\right)^{\frac{1-a}{2}} K_{a-1}(2\sqrt{cd})$$

we can evaluate the integral in (6) by setting $a = q - j + 1$, $c = \beta_p t$, $d = \alpha_i$. Thus we may write

$$\begin{aligned} f_Z(t) &= \sum_{p=1}^r \sum_{q=1}^{l_p} \sum_{i=1}^n \sum_{j=1}^{k_i} B_{pq} A_{ij} \frac{\beta_p^q \alpha_i^j t^{q-1}}{(q-1)! (j-1)!} 2 \left(\frac{\beta_p t}{\alpha_i}\right)^{\frac{j-q}{2}} K_{q-j}(2\sqrt{\alpha_i \beta_p t}) \\ &= \sum_{p=1}^r \sum_{q=1}^{l_p} \sum_{i=1}^n \sum_{j=1}^{k_i} B_{pq} A_{ij} \frac{2\beta_p^{\frac{q+j}{2}} \alpha_i^{\frac{q+j}{2}} t^{\frac{q+j}{2}-1}}{(q-1)! (j-1)!} K_{q-j}(2\sqrt{\alpha_i \beta_p t}) \\ &= \sum_{p=1}^r \sum_{q=1}^{l_p} \sum_{i=1}^n \sum_{j=1}^{k_i} B_{pq} A_{ij} \frac{2(\beta_p \alpha_i t)^{\frac{q+j}{2}}}{(q-1)! (j-1)! t} K_{q-j}(2\sqrt{\alpha_i \beta_p t}) \end{aligned}$$

By comparing the expression of PDF of the K -distribution defined in Lemma 1 , we can conclude that

$$\frac{2(\beta_p \alpha_i t)^{\frac{q+j}{2}}}{(q-1)! (j-1)! t} K_{q-j}(2\sqrt{\alpha_i \beta_p t})$$

is the PDF of a K -distribution with parameter q and j and mean $\mu_K = \frac{qj}{\alpha_i \beta_p}$, or we write $K \sim K(q, j, \frac{qj}{\alpha_i \beta_p})$. Therefore, the PDF of Z can be written as $f_Z(t) = \sum_{p=1}^r \sum_{q=1}^{l_p} \sum_{i=1}^n \sum_{j=1}^{k_i} B_{pq} A_{ij} f_K(t)$ where $f_K(t)$ is the PDF of $K(q, j, \frac{qj}{\alpha_i \beta_p})$.

The PDF of the product of two independent Hypoexponential distributions, given in Theorem 1, is proven to be a linear combination of the PDF of the K -distribution. However, some articles concentrated on finding the PDF of unknown distribution in this format as a linear combination of a PDF of more simple and known distribution see (Smaili, 2013a), (Smaili, 2013b), (Kadri, 2015a) and (Kadri, 2015b). Thus we can directly conclude the CDF, Reliability function, MGF, Moment of order m and the Expectation of this unknown distribution as a linear combination of CDF, Reliability function, MGF, Moment of order m and the Expectation of the known distribution respectively. In our paper this known distribution is the K -distribution and we presented it characteristics previously in Section 2. By applying the above idea we proved that the PDF of Z is

$$f_Z(t) = \sum_{p=1}^r \sum_{q=1}^{l_p} \sum_{i=1}^n \sum_{j=1}^{k_i} B_{pq} A_{ij} f_K(t)$$

thus we conclude that CDF of Z is

$$F_Z(t) = \sum_{p=1}^r \sum_{q=1}^{l_p} \sum_{i=1}^n \sum_{j=1}^{k_i} B_{pq} A_{ij} F_K(t)$$

where $F_K(t)$ is the CDF of K , and the Reliability function of Z is

$$R_Z(t) = \sum_{p=1}^r \sum_{q=1}^{l_p} \sum_{i=1}^n \sum_{j=1}^{k_i} B_{pq} A_{ij} R_K(t)$$

where $R_K(t)$ is the reliability function of K . Then we simply can find the hazard function from

$$h_Z(t) = \frac{f_Z(t)}{R_Z(t)}$$

that is computed directly from the K -distribution. Moreover, the MGF of Z is also a linear combination of the MGF of the K -distribution as

$$\Phi_Z(t) = \sum_{p=1}^r \sum_{q=1}^{l_p} \sum_{i=1}^n \sum_{j=1}^{k_i} B_{pq} A_{ij} \Phi_K(t) \tag{17}$$

and as a consequence the moment of order m of Z , which the m^{th} derivative of $\Phi_Z(t)$ at $t = 0$, shall have the following linear combination form

$$E[Z^m] = \sum_{p=1}^r \sum_{q=1}^{l_p} \sum_{i=1}^n \sum_{j=1}^{k_i} B_{pq} A_{ij} E[K^m] \tag{18}$$

and $E[K^m]$ is the moment of order m of K . Now with the expression of $\Phi_K(t)$ and $E[K^m]$ from Lemma 1 with K -distribution of parameters q, j and mean $\mu_K = \frac{qj}{\alpha_i \beta_p}$, where $K \sim K\left(q, j, \frac{qj}{\alpha_i \beta_p}\right)$, we get

$$\Phi_K(t) = \left(\frac{\alpha_i \beta_p}{t}\right)^{\frac{q+j-1}{2}} e^{\frac{\alpha_i \beta_p}{2t}} W_{-\frac{q+j-1}{2}, \frac{j-q}{2}}\left(\frac{\alpha_i \beta_p}{t}\right),$$

and

$$E[K^m] = \frac{\Gamma(q+m)\Gamma(j+m)}{\alpha_i^m \beta_j^m \Gamma(q)\Gamma(j)}.$$

Therefore, we obtain by substituting these expressions into (17) and (18) that

$$\Phi_Z(t) = \sum_{p=1}^r \sum_{q=1}^{l_p} \sum_{i=1}^n \sum_{j=1}^{k_i} B_{pq} A_{ij} \left(\frac{\alpha_i \beta_p}{t}\right)^{\frac{q+j-1}{2}} e^{\frac{\alpha_i \beta_p}{2t}} W_{-\frac{q+j-1}{2}, \frac{j-q}{2}}\left(\frac{\alpha_i \beta_p}{t}\right)$$

and

$$E[Z^m] = \sum_{p=1}^r \sum_{q=1}^{l_p} \sum_{i=1}^n \sum_{j=1}^{k_i} \frac{B_{pq} A_{ij} \Gamma(q+m)\Gamma(j+m)}{\alpha_i^m \beta_j^m \Gamma(q)\Gamma(j)}$$

On the other hand, by observing the mean of $Z = XY$, that has the form $E[Z] = E[X]E[Y]$. But the means of $X \sim Hypoexp(\vec{\alpha}, \vec{k})$ and $Y \sim Hypoexp(\vec{\beta}, \vec{l})$ are obtained from Eq. (8) as $E[X] = \sum_{i=1}^n \frac{k_i}{\alpha_i} = \sum_{i=1}^n \sum_{j=1}^{k_i} A_{ij} \frac{j}{\alpha_i}$ and $E[Y] = \sum_{p=1}^r \frac{l_p}{\beta_p} = \sum_{p=1}^r \sum_{q=1}^{l_p} B_{pq} \frac{q}{\beta_p}$. Then

$$\begin{aligned} E[Z] &= \sum_{i=1}^n \frac{k_i}{\alpha_i} \sum_{p=1}^r \frac{l_p}{\beta_p} \\ &= \sum_{i=1}^n \sum_{j=1}^{k_i} A_{ij} \frac{j}{\alpha_i} \sum_{p=1}^r \sum_{q=1}^{l_p} B_{pq} \frac{q}{\beta_p} \\ &= \sum_{i=1}^n \sum_{j=1}^{k_i} \sum_{p=1}^r \sum_{q=1}^{l_p} A_{ij} B_{pq} \frac{qj}{\beta_p \alpha_i} \end{aligned}$$

this expression verifies our expression of the moment of Z of order $m = 1$ in Eq. (18)

$$E[Z] = \sum_{p=1}^r \sum_{q=1}^{l_p} \sum_{i=1}^n \sum_{j=1}^{k_i} B_{pq} A_{ij} E[K]$$

however the mean of K is stated in Theorem 1 as $E[K] = \mu_K = \frac{qj}{\alpha_i \beta_p}$.

3.2 Particular cases

In this part, we consider the particular case of the Hypoexponential distribution when the Exponential stages are different. Let X and Y be two independent Hypoexponential random variables each distribution of different stages. Thus, $X \sim Hypoexp(\vec{\alpha})$, $\vec{\alpha} = (\alpha_1, \alpha_2, \dots, \alpha_n)$ and $Y \sim Hypoexp(\vec{\beta})$, $\vec{\beta} = (\beta_1, \beta_2, \dots, \beta_r)$, and then from Eq. (9) the PDF of X and Y are

$$f_X(t) = \sum_{i=1}^n A_i \alpha_i e^{-\alpha_i t} \text{ and } f_Y(t) = \sum_{p=1}^r B_p \beta_p e^{-\beta_p t} \tag{19}$$

respectively, with $A_i = \prod_{j=1, j \neq i}^n \left(\frac{\alpha_j}{\alpha_j - \alpha_i}\right)$ and $B_p = \prod_{j=1, j \neq p}^r \left(\frac{\beta_j}{\beta_j - \beta_p}\right)$.

Theorem 2: Let X and Y be two independent random variables with densities given in (19). Then the PDF of $Z = XY$ is given by

$$f_Z(t) = \sum_{i=1}^n \sum_{p=1}^r 2A_i B_p \alpha_i \beta_p K_0(2\sqrt{\alpha_i \beta_p t}).$$

and the CDF is

$$F_Z(t) = 1 - 2 \sum_{p=1}^r \sum_{i=1}^n B_p A_i \sqrt{\alpha_i \beta_p t} K_1(2\sqrt{\alpha_i \beta_p t})$$

Proof. From Theorem 1, we take the particular cases of the two Hypoexponential distributions when their stages are different. Then $\vec{k} = (1, 1, \dots, 1)$ and $\vec{l} = (1, 1, \dots, 1)$, this gives in the summation in Eq. (11) the only values are $j = q = 1$. Then the K -distribution is $K \sim K(1, 1, \mu_{i,p})$ where $\mu_{i,p} = \frac{1}{\alpha_i \beta_p}$. Thus, we have from Eq. (10)

$$f_K(t) = \frac{2}{\mu} K_0\left(2\sqrt{\frac{t}{\mu}}\right) = 2\alpha_i \beta_p K_0(2\sqrt{\alpha_i \beta_p t})$$

Moreover, knowing that in this particular case $B_{pq} = B_p$ and $A_{ij} = A_i$, we obtain the given form of PDF of Z as

$$f_Z(t) = \sum_{i=1}^n \sum_{p=1}^r 2A_i B_p \alpha_i \beta_p K_0(2\sqrt{\alpha_i \beta_p t}).$$

On the other hand, the expression of the CDF in this manner is complicated because of the unknown primitive of $K_0(2\sqrt{\alpha_i \beta_p t})$. So we shall use the other approach in finding the CDF from the its definition from the product distribution formula in (1) as

$$F_Z(t) = E\left[F_Y\left(\frac{t}{x}\right)\right]$$

However, the CDF of $Y \sim \text{Hypoexp}(\vec{\beta})$ is $F_Y(x) = 1 - \sum_{p=1}^r B_p e^{-\beta_p x}$. Thus

$$\begin{aligned} F_Z(t) &= E\left[1 - \sum_{p=1}^r B_p e^{-\beta_p \frac{t}{x}}\right] \\ &= 1 - \int_0^\infty \left(\sum_{p=1}^r B_p e^{-\beta_p \frac{t}{x}}\right) f_X(x) dx \\ &= 1 - \int_0^\infty \left(\sum_{p=1}^r B_p e^{-\beta_p \frac{t}{x}}\right) \left(\sum_{i=1}^n A_i \alpha_i e^{-\alpha_i x}\right) dx \\ &= 1 - \int_0^\infty \left(\sum_{p=1}^r \sum_{i=1}^n B_p A_i \alpha_i e^{-\frac{\beta_p t}{x} - \alpha_i x}\right) dx \\ &= 1 - \sum_{p=1}^r \sum_{i=1}^n B_p A_i \alpha_i \int_0^\infty \left(e^{-\frac{\beta_p t}{x} - \alpha_i x}\right) dx \end{aligned}$$

However, the integral in the summation can be obtained from

$$\int_0^{+\infty} e^{-\frac{m}{x} - nx} dx = 2\sqrt{\frac{m}{n}} K_1(2\sqrt{mn})$$

Therefore, we get

$$\begin{aligned} F_Z(t) &= 1 - \sum_{p=1}^r \sum_{i=1}^n B_p A_i \alpha_i 2\sqrt{\frac{\beta_p t}{\alpha_i}} K_1(2\sqrt{\alpha_i \beta_p t}) \\ &= 1 - 2 \sum_{p=1}^r \sum_{i=1}^n B_p A_i \sqrt{\alpha_i \beta_p t} K_1(2\sqrt{\alpha_i \beta_p t}) \end{aligned}$$

We also can conclude for this case of XY , the reliability function is

$$R_Z(t) = 2 \sum_{p=1}^r \sum_{i=1}^n B_p A_i \sqrt{\alpha_i \beta_p t} K_1(2\sqrt{\alpha_i \beta_p t})$$

and thus the hazard function is

$$h_Z(t) = \frac{\sum_{i=1}^n \sum_{p=1}^r A_i B_p \alpha_i \beta_p K_0(2\sqrt{\alpha_i \beta_p t})}{\sum_{i=1}^n \sum_{p=1}^r A_i B_p \sqrt{\alpha_i \beta_p t} K_1(2\sqrt{\alpha_i \beta_p t})}$$

4. APPLICATION: PROBABILITY DISTRIBUTION ON THE TOTAL EXECUTION TIME IN STOCHASTIC PERT NETWORK.

In this real life application, we will apply our theoretical result to stochastic activity network used in project management. In a project management a well known management tool called PERT is used to schedule, organize, and coordinate tasks within a project. PERT stands for Program Evaluation Review Technique, a methodology developed by the U.S. Navy in the 1950s to manage the Polaris submarine missile program. A PERT chart is a graphic representation of a project's schedule, showing the sequence of tasks, which tasks can be performed simultaneously, and the critical path of tasks that must be completed on time in order for the project to meet its completion deadline. The chart can be constructed with a variety of attributes, such as earliest and latest start dates for each task, earliest and latest finish dates for each task, and slack time between tasks.

Example of project using PERT technique:

Task	Predecessors	Realistic time estimate (day)
S	None	None
A	S	5
B	A	2
C	G	1
D	C	3
E	B and D	5 and 11
F	E	3
G	S	15

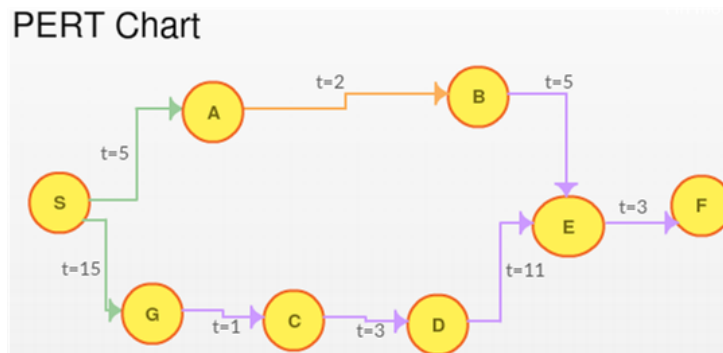

Fig.1: The PERT chart representing a projects schedule showing the sequence of tasks that can be run in parallel and in series

From the chart we can see that some tasks can be run in parallel other in series and some of them can't be run before the termination of others. For certain task durations, a simple algorithm gives the total time required to finish the project. For uncertain task durations, which are the real life situation, we consider the task durations as random variables. The normal assumption is that these durations are described by independent distributions. In this case, a critical interest in the PERT analysis is the distribution of the random variable describing the project's duration. For all tasks appearing in series, the total activity duration for that series is the sum of the random variables corresponding to each project task. Let us assume the durations of each task are independent exponential variables with different parameters, $X = X_S + X_A + X_B + X_E$, and $Y = Y_S + Y_G + Y_C + Y_D + Y_E$.

In this application, we are interested to evaluate analytically the probability distribution of the total time of execution required to finish the project, which can be achieved by considering the random variable XY .

Numerical Examples: X is a sum of independent exponential variables, X_S, X_A, X_B , and X_E with different parameter 5,2 and 3 respectively. Then X follows a Hypoexponential distribution with different parameters. That is, $X \sim Hypoexp(\vec{\alpha}, \vec{k})$, $\vec{\alpha} = (5,2,3)$, $\vec{k} = (2,1,1)$. and the PDF of X is $f_X(t) = \sum_{i=1}^3 \sum_{j=1}^{k_i} A_{ij} f_{E_{\alpha_{ij}}}(t)$ and using the formulas (6) and (7) gives that $A_{11} = 25/6$, $A_{21} = 1$, $A_{31} = 25/3$, $A_{31} = -25/2$. Also Y is a sum of independent exponential variables, Y_S, Y_G, Y_C, Y_D

and Y_E with different parameter 15, 1, 3, 11, and 3 respectively. Then Y follows a Hypoexponential with different parameters. That is, $Y \sim \text{Hypoexp}(\vec{\beta}, \vec{l})$, $\vec{\beta} = (15, 1, 3, 11)$, $\vec{l} = (1, 1, 2, 1)$ and the PDF of Y is $f_Y(t) = \sum_{p=1}^4 \sum_{q=1}^{l_p} B_{pq} f_{E_{\beta_p, q}}(t)$. Also the formulas (6) and (7) gives that, $B_{11} = 11/896$, $B_{21} = 297/112$, $B_{31} = -385/512$, $B_{32} = -55/64$, $B_{41} = -27/512$.

Next, we shall determine the PDF of XY using Theorem 1,

$$f_Z(t) = \sum_{i=1}^{n=3} \sum_{j=1}^{k_i} \sum_{p=1}^{r=4} \sum_{q=1}^{l_p} A_{ij} B_{pq} f_K(t)$$

where

$$f_K(t) = \frac{2(\beta_p \alpha_i t)^{\frac{q+j}{2}}}{(q-1)!(j-1)!t} K_{q-j}(2\sqrt{\alpha_i \beta_p t})$$

The function is implemented into MATHEMATICA, and the graph is shown in Fig. 2.

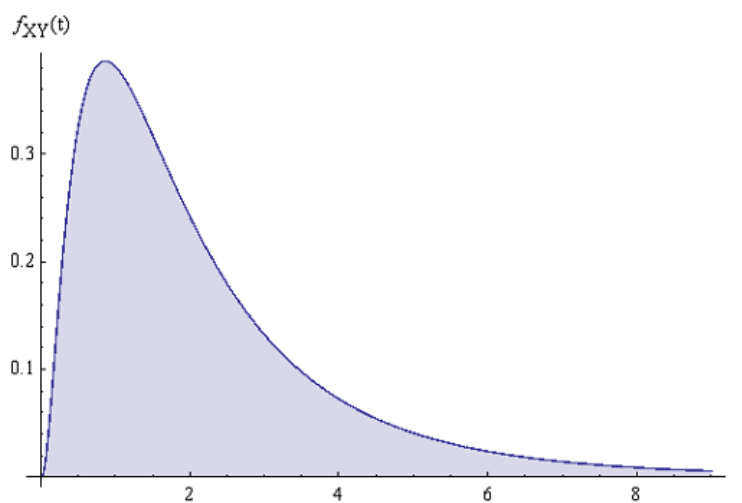

Fig.2: The probability distribution of the total time of execution required to finish the project

5. CONCLUSIONS

The exact expressions of the probability density function of the product of two independent general case of the Hypoexponential distribution and particular two independent Hypoexponential distribution of different stages are obtained. The expressions are given as a linear combination of the K -distribution. As a consequence, the CDF, reliability function, hazard function, MGF and moment of order m are established. Eventually, a theoretical result is applied to stochastic activity network used in project management by determining the total execution time in stochastic PERT Network.

REFERENCES

- Abu-Salih, M. S. (1983). Distributions of the product and the quotient of power-function random variables. *Arab J. Math*, 4, 1-2.
- Abramowitz, M., & Stegun, I. A. (1965). Handbook of mathematical functions with formulas, graphs, and mathematical table. In *US Department of Commerce*. National Bureau of Standards Applied Mathematics series 55.
- Barry, L. (2002). *Postmodernism and Literature*. London: Routledge.
- Bhargava, R. P., & Khatri, C. G. (1981). The distribution of product of independent beta random variables with application to multivariate analysis. *Annals of the Institute of Statistical Mathematics*, 33(1), 287-296.
- Coelho, C. A., & Mexia, J. T. (2007). On The Distribution of The Product And Ratio of Independent Generalized Gamma-Ratio Random Variables. *Sankhyā: The Indian Journal of Statistics*, 221-255.
- Herrington, A. J. (1985). Classrooms as Forums for Reasoning and Writing. *College Composition and Communication*, 36(4), 404-413.

- Harter, H. L. (1951). On the Distribution of Wald's Classification Statistic. *The Annals of Mathematical Statistics*, 22(1), 58-67.
- Jakeman, E., & Pusey, P. N. (1978). Significance of K Distributions in Scattering Experiments. *Physical Review Letters*, 40(9), 546.
- Kadri, T., & Smaili, K. (2015). Convolutions of Hyper-Erlang and of Erlang Distributions. *International Journal of Pure and Applied Mathematics*, 98(1), 81-98.
- Kadri, T., Smaili, K., & Kadry, S. (2015). Markov Modeling for Reliability Analysis Using Hypoexponential Distribution. In *Numerical Methods for Reliability and Safety Assessment* (pp. 599-620). Springer, Cham.
- Malik, H. J., & Trudel, R. (1986). Probability Density Function of the Product and Quotient of Two Correlated Exponential Random Variables. *Canadian Mathematical Bulletin*, 29(4), 413-418.
- Nadarajah, S. (2007). The Linear Combination, Product and Ratio of Laplace Random Variables. *Statistics*, 41(6), 535-545.
- Pham-Gia, T., & Turkkan, A. N. (2002). Operations on the Generalized-F Variables and Applications. *Statistics*, 36(3), 195-209.
- Podolski, H. (1972). The Distribution of a Product of an Independent Random Variables with Generalized Gamma Distribution. *Demonstratio Mathematica*, 4(2), 119-124.
- Rathie, P. N., & Rohrer, H. G. (1987). The Exact Distribution of Products of Independent Random Variables. *Metron*, 45, 235-245.
- Redding, N. J. (1999). *Estimating the parameters of the K distribution in the intensity domain* (No. DSTO-TR-0839). Electronics Research Lab Salisbury (Australia).
- Rohatgi, V. K. (1976). Sample moments and their distributions. *An Introduction to Probability Theory and Mathematical Statistics*. John Wiley & Sons, New York.
- Sakamoto, H. (1943). On The Distributions of the Product and the Quotient of the Independent and Uniformly Distributed Random Variables. *Tohoku Mathematical Journal, First Series*, 49, 243-260.
- Smaili, K., Kadri, T., & Kadry, S. (2013). Hypoexponential Distribution with Different Parameters. *Applied mathematics*, 4(04), 624.
- Smaili, K., Kadri, T., & Kadry, S. (2014). A Modified-Form Expressions for the Hypoexponential Distribution. *British Journal of Mathematics & Computer Science*, 4(3), 322-332.
- Springer, M. D., & Thompson, W. E. (1970). The Distribution of Products of Beta, Gamma and Gaussian Random Variables. *SIAM Journal on Applied Mathematics*, 18(4), 721-737.
- Steece, B.M. (1976) On the Exact Distribution for the Product of Two Independent Beta-Distributed Random Variables. *Metron*, 34, 187-190.
- Stuart, A. (1962). Gamma-Distributed Products of Independent Random Variables. *Biometrika*, 49(3-4), 564-565.
- Tang, J., & Gupta, A. K. (1984). On The Distribution of the Product of Independent Beta Random Variables. *Statistics & Probability Letters*, 2(3), 165-168.
- Wallgren, C. M. (1980). The Distribution of the Product of Two Correlated T Variates. *Journal of the American Statistical Association*, 75(372), 996-1000.
- Ward, K. D. (1981). Compound Representation of High Resolution Sea Clutter. *Electronics letters*, 17(16), 561-563.
- Withers, C. S., & Nadarajah, S. (2013). On The Product of Gamma Random Variables. *Quality & Quantity*, 47(1), 545-552.